

## Tyvi-services and beyond (Finland)

Networked Business and Government –  
Something Real for the Lisbon Strategy

Finland's EU Presidency Conference in  
Helsinki 23-24 October, 2006  
House of the Estates

Kalevi Heiliö  
National Tax Board of Finland

### I Tyvi model 1997-2006

- Tyvi model is to use intermediaries (brokers) to collect information for many authorities
- Limited investment costs and private/public partnership as a starting point
- No actual incentives nor mandatories
- Several collection channels
  - Web Forms
  - File uploads
  - Loadable client module with initial data validations
  - Xml/soap trials
- Multi-recipient data collection
- Joint-up Government approach

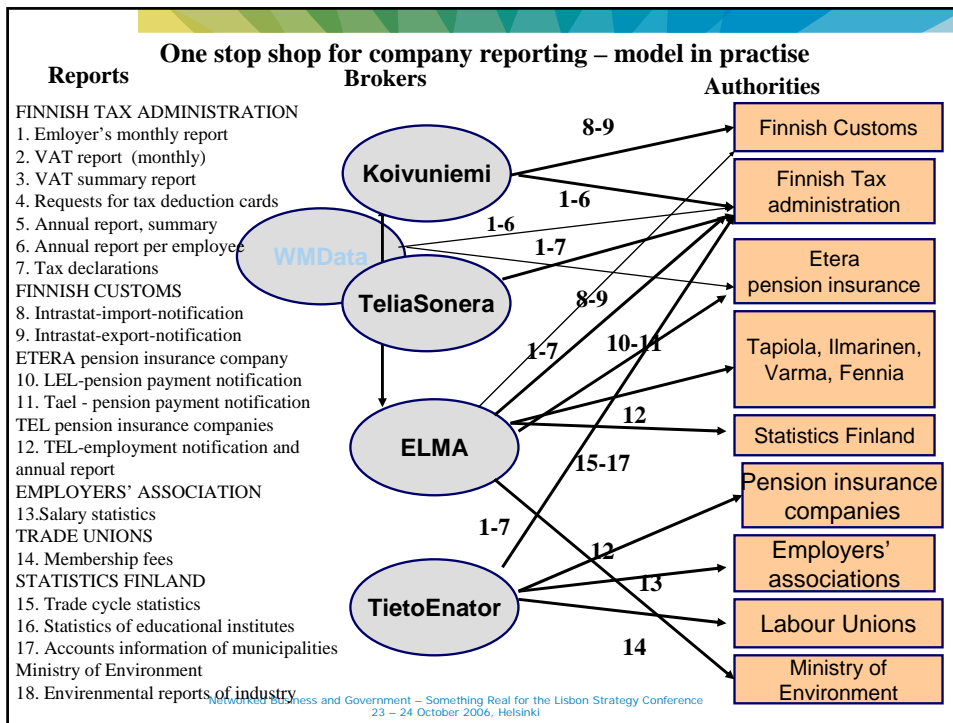

### Tyvi/Tax Collection results 2002-2006

Item/Year	2002	2003	2004	2005	2006 (preliminary estimation)
Monthly tax returns	547 000	754 000	1 219 000	1 963 000	2 500 000
Quarterly VAT summary Declarations	5 200	5 200	8 700	15 000	25 000
Employees' Annual Declarations	1 420 000	1 980 000	3 137 000	3 931 000	4 300 000
Tax Cards for withholding	1 630 000	2 141 000	2 994 000	3 178 000	3 300 000
Company Income Tax Declarations	1 400	3 100	8 600	17 545	40 000
The amount of companies involved	50 000	60 000	100 000	140 000	180 000

Networked Business and Government – Something Real for the Lisbon Strategy Conference  
23 – 24 October 2006, Helsinki

## II More than just Collection: Common Internet Payroll Portal

- New Internet service [www.palkka.fi](http://www.palkka.fi) opened for public use 1.2.2006
- Smallest Enterprises and Households can for free use payroll service that makes most of the employer's basic payroll work
- Salary and withholding routines
- Electronic payments (employees and authorities)
- Automatic electronic reporting
- Complete set of output forms
- Tutorial mode and examples
- Targeted for
  - 60 000 enterprises with 1-5 employees
  - 200 000 households

Networked Business and Government – Something Real for the Lisbon Strategy Conference  
23 – 24 October 2006, Helsinki

### Palkka.fi Spots:

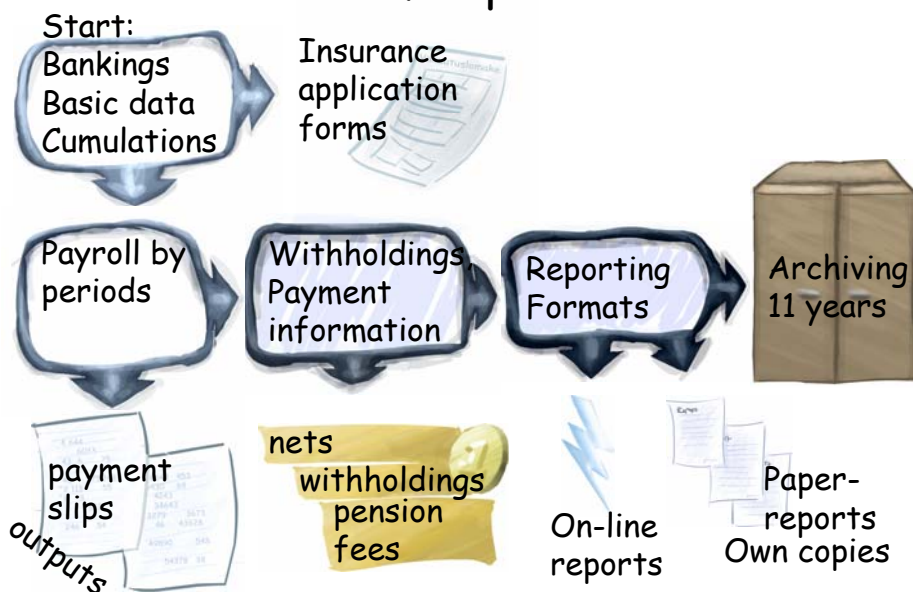

Networked Business and Government – Something Real for the Lisbon Strategy Conference  
23 – 24 October 2006, Helsinki

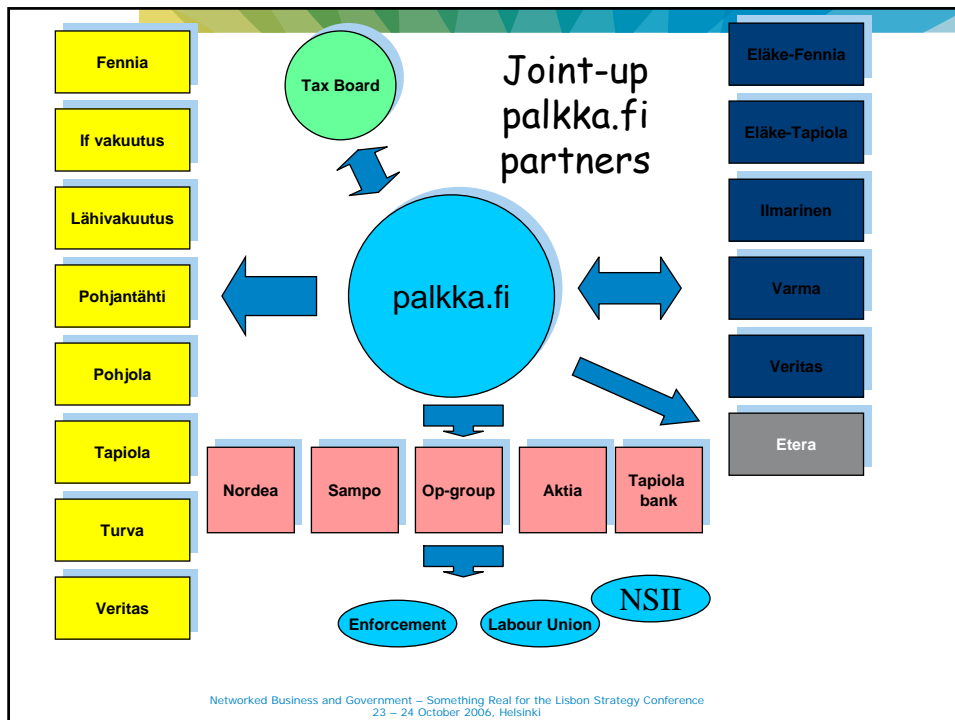

## palkka.fi progress so far

- Now registered (every day more) about
  - - 4000 businesses
  - - 6000 households
- Thousands of visitors
- Goal up to end 2006: 15.000 users
- Goal for 2007: 30.000 users
- Palkka.fi is main Tax strategy to low end
- A lot of further extensions on the list:
  - upgrade paths to other services
  - more integrated payment methods
  - bookkeeping integration
  - inbound & outbound e-invoicing

### III NexTyvi for next years

- Direct Reporting from SW packet instances by web services (xml/soap)
- Target group about 150 SW developers and a number of in-house solutions
- Liberty Alliance SAML approach (Service Access Markup Language)
- No brokers
- Immediate checks and feedback
- A base for common eGovernment service
- Key integration tool
- Based on common identification service

Networked Business and Government – Something Real for the Lisbon Strategy Conference  
23 – 24 October 2006, Helsinki

### NexTyvi Data Delivery Model

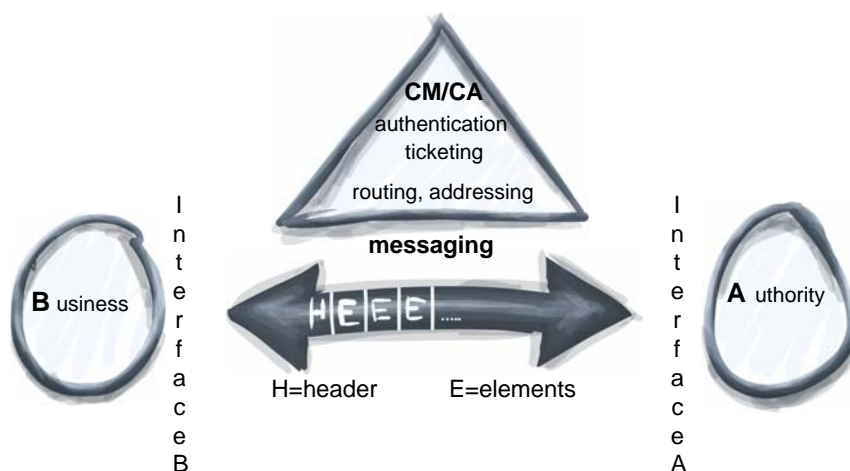

Networked Business and Government – Something Real for the Lisbon Strategy Conference  
23 – 24 October 2006, Helsinki

## SAML message exchange sequence

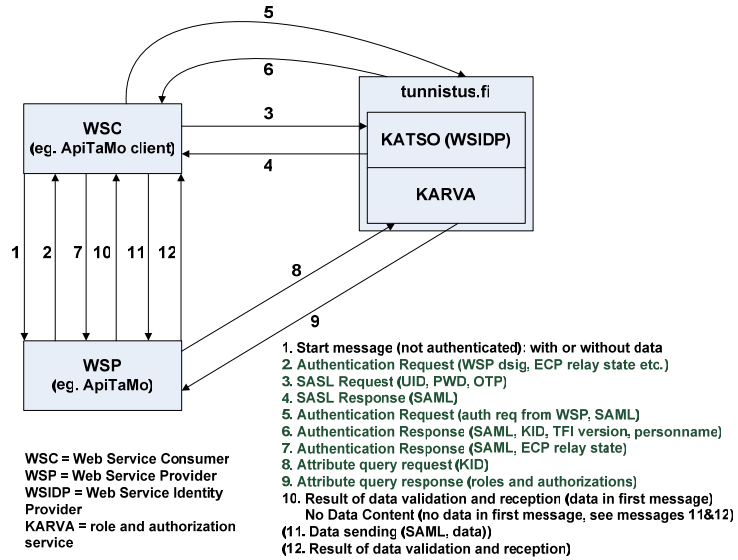

Networked Business and Government – Something Real for the Lisbon Strategy Conference  
23 – 24 October 2006, Helsinki

## ApiTaMo example

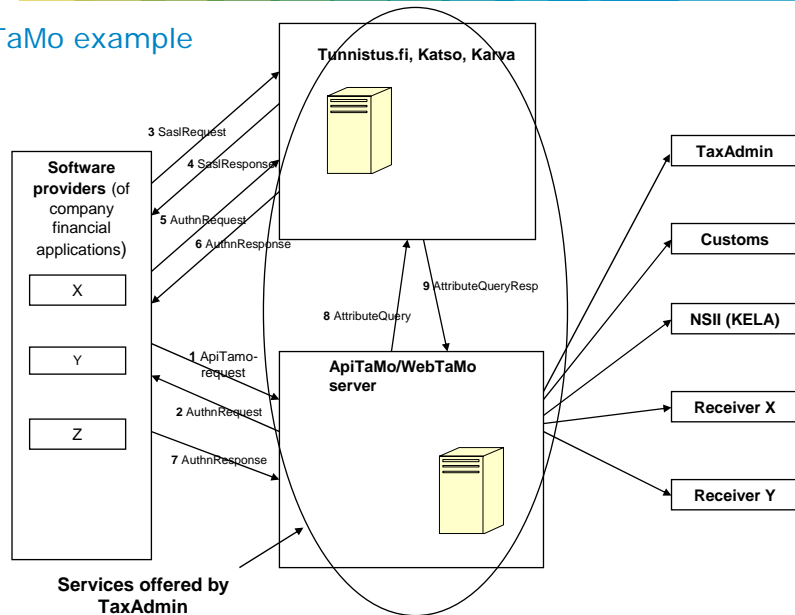

Networked Business and Government – Something Real for the Lisbon Strategy Conference  
23 – 24 October 2006, Helsinki



[Help](#)  
[Suomeksi](#) | [På Svenska](#)

---

### Create IDs

- I'd like to set up a Master User for the organization. [Open »](#)
- I'd like to convert my Tyvi ID into a Katso ID. [Open »](#)
- I have been notified of an initialized Katso ID and I'd like to activate it. [Open »](#)
- I have a limited Katso ID that I'd like to strengthen so it becomes a Katso ID. [Open »](#)
- I'd like to transfer the Master User right to myself. [Open »](#)

### Katso ID management

- I already have a Katso ID. I want to manage my information and authorizations. [Open »](#)

### Manage IDs

- My Katso ID is locked but I'd like to reactivate it. [Open »](#)
- I'd like to lock my Katso ID until further notice. [Open »](#)
- I have forgotten my Katso ID (completely or in part), and I'd like to get it back. [Open »](#)
- I want a new Password and/or a new List of One-Time Passwords. [Open »](#)

Networked Business and Government – Something Real for the Lisbon Strategy Conference  
 23 – 24 October 2006, Helsinki

## NexTyvi potentials (a vision)

- Common communication model in and out
- Concept of thematic addresses
  - www-address
  - IP-address
  - email-address(es)
  - eInvoice-address(es)
  - PIP-address (Partner Interface Procedures)
- Concept of Networking Semaphores
  - Standard Initialisation Points
  - Open/Wait/Close statuses
- Automated Party agreements
  - Seamless Production chains at large

Networked Business and Government – Something Real for the Lisbon Strategy Conference  
 23 – 24 October 2006, Helsinki

## Three (3) main obstacles slowing Europe's competitiveness down

- Obstacle 1: To be stick to Digital Signature
- Obstacle 2: Lack of e-Europe leadership
- Obstacle 3: Too many strategy papers and groups just producing new papers and groups

**All speakers are invited to present**

**a)** three concrete measures to boost European competitiveness through the effective utilization of ICT and public-private partnerships. We are looking for measures that are quick to implement – with direct effects to citizens, companies and public administration in the development, take up and expansion of innovations.

**b)** three main obstacles that are currently slowing Europe's competitiveness down.

Vote for the seminar audience to identify three most important measures from the whole session.

Networked Business and Government – Something Real for the Lisbon Strategy Conference  
23 – 24 October 2006, Helsinki

## Three (3) concrete measures to boost Europe's competitiveness

- Measure 1: Full support to Web Services and funding of common Web Service modules
- Measure 2: Building European Communication Highway, that is very powerfull VPN-backbone
- Measure 3: Leashing the public sector as a leading Horse of the Mobile society.

**All speakers are invited to present**

**a)** three concrete measures to boost European competitiveness through the effective utilization of ICT and public-private partnerships. We are looking for measures that are quick to implement – with direct effects to citizens, companies and public administration in the development, take up and expansion of innovations.

**b)** three main obstacles that are currently slowing Europe's competitiveness down.

Vote for the seminar audience to identify three most important measures from the whole session.

Networked Business and Government – Something Real for the Lisbon Strategy Conference  
23 – 24 October 2006, Helsinki